



TREVOR-MARTIN CORPORATION



INSTALLATION/OPERATING INSTRUCTIONS

FOR

AQUEFIER POOL HEATERS

Model TM121 / WCC115

IMPORTANT SAFETY INSTRUCTIONS

READ AND FOLLOW INSTRUCTIONS

SAVE THESE INSTRUCTIONS

TO THE HOMEOWNER

Congratulations on your decision to purchase an AQUEFIER Pool Heater. The AQUEFIER Pool Heater is designed to heat your swimming pool by taking heat from the air in your backyard and transferring it into your pool. The process is done with amazing efficiency; and without the smelly combustion by-products from potentially dangerous natural gas or propane.

Your AQUEFIER Pool Heater operates in conjunction with your pool filter pump. Once you, or your pool timer turn the pump on, the AQUEFIER Pool Heater starts up, measures the water temperature in your pool, compares it to your chosen pool temperature, and starts adding heat if required. If desired, the AQUEFIER Pool Heater will keep your pool pump running until it reaches your chosen temperature, even if the pool timer turns off.

CAUTIONS / DISCLAIMERS

The AQUEFIER Pool Heater operates in conjunction with your pool equipment. Improper installation can cause damage to both your Pool Heater, your pool pump, and filter piping. Only skilled technicians with appropriate training and experience should perform the installation. The Manufacturer accepts no liability for equipment damage, personal property damage, or personal injury arising from the improper installation of this pool heater.

The installation must be in compliance with local codes and ordinances.

Wiring should only be done by licensed electricians.

Local Plumbing, Mechanical and Electrical Codes take precedence over any instructions contained herein.

SPECIAL NOTE: Installations subject to freezing ambient temperatures must make provisions for freeze protection to avoid damage to this appliance. The safest method of freeze protection is to provide for draining of the heat exchanger and water lines. Freeze damage is specifically excluded from the Warranty for this appliance.

IMPORTANT SAFETY INSTRUCTIONS

When using this electrical equipment, basic safety precautions should always be followed, including the following:

1. READ AND FOLLOW ALL INSTRUCTIONS.
2. To reduce the risk of injury:
 - a. The water in a pool or tub should never exceed 104 degrees F. A water temperature in excess of 104 degrees F is considered unsafe for all persons. Lower water temperatures are recommended for extended use (exceeding 10 – 15 minutes) and for young children.
 - b. Since excessive water temperatures have a high potential for causing fetal damage during the early months of pregnancy, pregnant or possibly pregnant women should limit pool or tub water temperatures to 100 degrees F.
 - c. Before entering a pool or tub, the user should measure the water temperature at several occupant locations using an accurate thermometer since the tolerance of the water temperature-regulating devices may vary as much as + or – 5 degrees F.
 - d. Alcohol, drugs, or medication should not be used before or during pool or tub use since their use may lead to unconsciousness with the possibility of drowning.
 - e. Obese persons and persons with a medical history of heart disease, low or high blood pressure, circulatory system problems, or diabetes should consult a physician before using a pool or tub.
 - f. Persons using medication should consult a physician before using a pool or tub since some medications may induce drowsiness while other medications may affect heart rate, blood pressure, and circulation.
3. SAVE THESE INSTRUCTIONS.

LOCATING THE POOL HEATER FOR INSTALLATION

The AQUEFIER Pool Heater must be installed outside near the pool pump/filter on a level area. Special care must be taken to ensure that air flow is not restricted on the side air inlets, the heat pump coil, or the top air discharge. Allow at least 12 inches clearance on all sides and 4 feet clearance on top of the Pool Heater. Good Practice suggests allowing at least 4 feet of clearance on the front of the Pool Heater for service access.

The unit should be set on a solid, level foundation, preferably a concrete slab at least 4 inches thick. The slab should be above ground level and surrounded by a graveled area good for drainage **since water will condense on the outside of the unit during normal operation.** The slab used as a unit foundation should not adjoin the building, as it is possible that sound and vibration may be transmitted to the structure.

Other location considerations include:

1. Keep the Pool Heater at least 10 to 15 feet away from pool chemical storage to minimize effects of corrosive chemical vapors, particularly chlorine vapors.
2. Allow for proper drainage of condensation formed by the normal operation of the heat pump.
3. Do not install the Pool Heater in an enclosed area, such as a filter equipment room. It is important to prevent the cool discharge air from being drawn back into the heat pump.

A beach location presents additional concerns. Exposure to salt water spray and high winds will cause premature wear on the heat pump. Salt and sand accumulation will clog up the heat pump coil, causing both corrosion and severely reduced efficiency. Preventive measures include: building a windbreak around the heat pump; raise the pool heater up off the beach to reduce sand being sucked in; increased frequency of cleaning of the fan motor and heat pump coil.

Finally, special care must be taken to check the elevation of the Pool Heater relative to the pool water level. The AQUEFIER Pool Heater uses a pressure switch to determine that water flow is present. If the Pool Heater is located more than 3 feet below the pool water level, or if the pool piping passes more than 3 feet above the water inlet of the Pool Heater, the Pool Heater's pressure switch can be fooled into a false reading. This will result in the Pool Heater starting up without water flow, and potentially damaging the Heater. Furthermore, an excessively dirty filter can reduce the water flow enough to prevent the pressure switch from turning the Pool Heater on.

INSTALLING THE POOL HEATER

Pool Heater installation is divided into two sections: **electrical connections, and pool piping connections.** The Factory has fully installed the refrigeration loop and preset the controls. There are no job-site installation requirements for the heat pump. **Wiring should only be done by licensed electricians.**

ELECTRICAL CONNECTIONS

Power to the Pool Heater

The AQUEFIER Pool Heater requires a separate 230 volt, 50 amp. circuit with a breaker, and a ground connection. The pool heater grounding conductor shall be the same size or larger than the live power supply conductors. See Figure 1 – Electrical Connections. For reference see Figure 3A, Pool Heater 230 VAC Schematic.

Use a length of watertight flexible conduit to connect to the Pool Heater cabinet. Enter the Pool Heater cabinet through the openings provided at the right /rear corner of the cabinet. Remove the control box cover panel and connect directly to the **compressor contactor** inside the control box. Ground the heat pump per local codes.

This pool heater is to be installed in accordance with Article 680 of the National Electrical Code, ANSI/NFPA 70, and with the requirements of the authority having jurisdiction.

Bonding to Pool Steel: Electrical corrosion, known as electrolysis, will occur if the heater is not bonded to the pool reinforcement steel. Most local codes also require that the water pump be bonded. Connect using a #8 gauge or larger solid copper wire to bond the cabinet to the pool reinforcement steel.

Power to the Pool Pump

An optional feature on the Aquifier Pool Heater is the **Pump Hold Relay**. Since **the pool heater can not run without water flow**, the **Pump Hold Relay** will keep the pool pump and the pool heater running until the pool has reached the desired temperature setpoint. If the pump hold relay is not wired in, the heater can only run when the pump is either turned on manually, or by the pump timer.

To wire this optional feature in, the pool heater requires a circuit from the pool pump timer to the pool heater, and a circuit from the pool heater to the pool pump. See Figure 2, Pool Pump to Hold Relay Wiring Schematic. The Pump Hold Relay can be used with either a 120 volt or a 230 volt, 1 phase pump, with current draws up to 25 amps. It should be noted that power to the pump can be supplied by the Timer and the Pump Hold Relay at the same time. The polarity of both sources of power to the pump must be the same. See Figures 1 and 2. The power supply to the timer and the pump hold relay must come from the same breaker.

1. Wiring must be sized per National Electrical Code requirements based on the pump load and conductor length.
2. Conductors must be installed in approved conduit.
3. The pool heater, the pool pump, and the pump timer must be grounded per National Electrical Code requirements.

Open the pool timer and connect a second set of wires to the line side terminals. Use a length of watertight flexible conduit to connect to the Pool Heater cabinet, entering through the openings provided on rear of the cabinet. Remove the left panel from the pool heater. Connect to the black wires labeled #1 and #2 hanging from the Pool Heater's control box.

Open the junction box on the pool pump and connect a second set of wires to the pump terminals. Use a length of watertight flexible conduit to connect to the Pool Heater cabinet, entering through the openings provided on the rear of the cabinet. Connect to the pair of blue wires, labeled #1 and #2, found hanging from the Pool Heater's control box. Be sure that the polarity is correct.

Replace the left panel on the cabinet.

POOL PIPING CONNECTIONS

The Pool Heater is designed to handle the full flow from the pool pump. No bypass is required if the water flow is in the 20 to 80 gallon per minute range. See Figure 4.

The Pool Heater piping must be connected at a point in the pool piping loop after the pool water passes through the filter and before the chlorinator or chemical feeder. Connecting the Pool Heater after the chlorinator will cause premature failure of the Pool Heater. **While this unit contains a specially coated heat exchanger to resist chlorine, failure to maintain proper pool chemistry will significantly shorten the life of the Pool Heater and may not be covered under Factory Warranty.** To prevent back-siphoning of the chlorinator when the pool pump is turned off, install a chemically resistant check valve and a piping loop that extends at least 8 inches above the top of the chlorinator.

The Pool Heater comes equipped with clear PVC stubs to allow a visual check of water flow and water condition. Connect to these stubs with 2 inch PVC couplings and an appropriate length of 2-inch PVC pipe; taking care to note which stub is "water in" and which is "water out".

Good practice also suggests considering the use of 3 way valves on the inlet and outlet to enable the pool owner to bypass the Pool Heater if service or maintenance is required.

OPERATING THE POOL HEATER

The AQUEFIER Pool Heater is designed to be easy to operate. The front panel contains a digital temperature control readout. The Pool Heater is set to reach and then maintain the selected pool water temperature, **as long as the pool pump is running**. Once the selected pool temperature has been reached, control of the pool pump is returned to the pool timer. The Pool Heater will, if installed to use the pump hold relay, keep the pool pump running if the timer shuts off before the selected temperature is reached.

NOTE: The Pool Heater will not run without water flow.

Water Temperature Control

For description of temperature control operation see appendix, Viconics HP727-S. After adjusting the temperature control, check the water temperature with an accurate thermometer. It may be necessary to calibrate the Viconics controller in rare instances.

CAUTION: Prolonged immersion in hot water may induce hyperthermia.

Hyperthermia occurs when the internal temperature of the body reaches several degrees above the normal body temperature of 98.6 degrees F. The symptoms of hyperthermia include dizziness, fainting, drowsiness, lethargy, and an increase in the internal temperature of the body. The effects of hyperthermia include:

- Unawareness of impending hazard;
- Failure to perceive heat;
- Failure to recognize the need to exit the pool or tub;
- Physical inability to exit the pool or tub;
- Fetal damage in pregnant women; and
- Unconsciousness resulting in danger of drowning.

WARNING: The use of alcohol, drugs, or medication can greatly increase the risk of fatal hyperthermia in pools and tubs.

Sequence of Operation

The control system includes **a time delay to accurately check the pool water temperature, and an anti-cycle timer to protect the compressor.**

The time delay allows the control to get an accurate reading of the pool water temperature.

The water in the heater may be hotter or colder than the water in the pool depending on weather conditions. To measure pool water temperature accurately, the time delay allows the pool pump to run for approximately 5 minutes before it measures temperature.

If there is a call for heat, the control will check to see if the compressor has been running during the last 3 minutes. If the heater has been off for more than 3 minutes, the heater will start immediately. If the heater has been either on during the last 3 minutes, or if power has been interrupted during the last 3 minutes, the heater will not be allowed to start for an additional 3 minutes.

The heater will not start until at least 5 minutes has passed without resetting the breakers.

The heater will continue to heat the pool until the temperature setpoint has been satisfied.

PLEASE NOTE:

1. It is important to remember that the pool heater will not run unless the pool pump is running.
2. Water vapor will condense on the outside of the unit and drain during normal operation.
3. There is up to a **5 minute start delay** built into the controls to prevent the compressor short cycling, and to assure that the temperature control is reading the pool water temperature accurately.
4. Raising the temperature control set point above the pool water temperature will not cause the heat pump to start up until the delay has been satisfied.
5. The digital temperature control will read the current pool water temperature whenever there is power to the heat pump. The temperature reading is not necessarily accurate unless the pool pump is moving water through the Pool Heater.

Pool Heater Operating Conditions:

Water Side Pressure Drop

Water Flow (gal./min.)	Pressure Drop (psig)
20	0.23
30	0.46
40	0.74
50	1.06
60	1.42
70	1.86
80	2.32

Temperature Rise Across Heater

Water Flow (gal./min.)	Temperature Rise (deg. F)
20	10.0
30	6.7
40	5.0
50	4.0
60	3.3
70	2.8
80	2.5

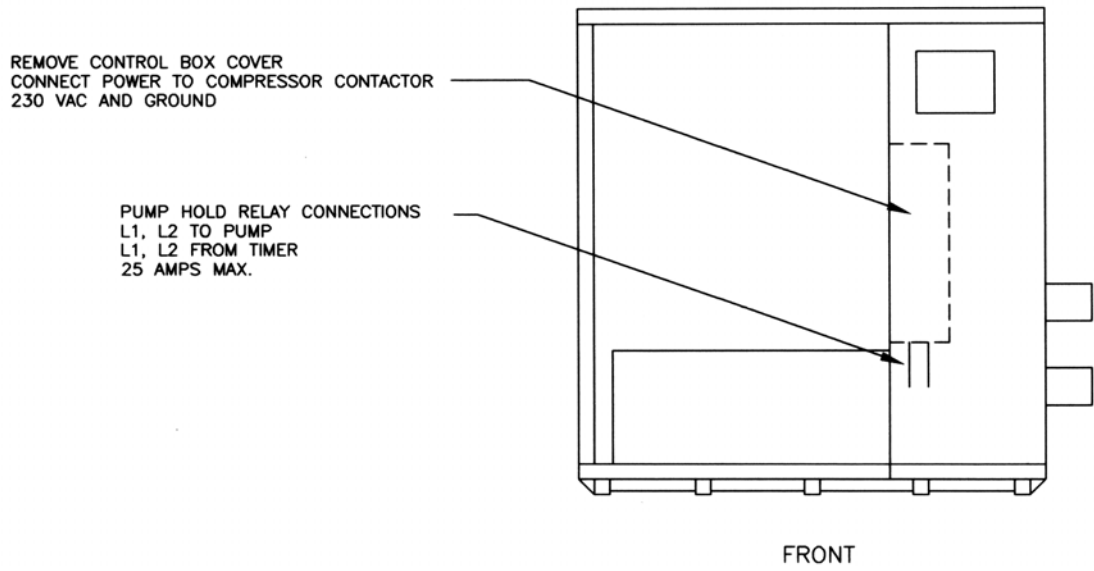

FIGURE 1 – ELECTRICAL CONNECTIONS
HEAT PUMP WITH LEFT PANEL REMOVED

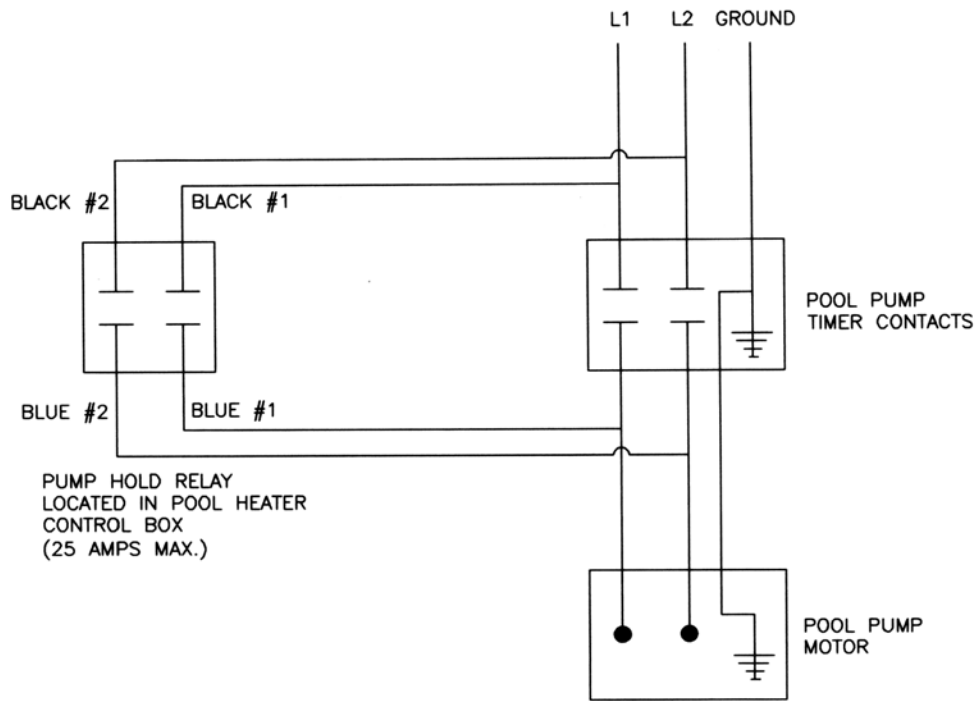
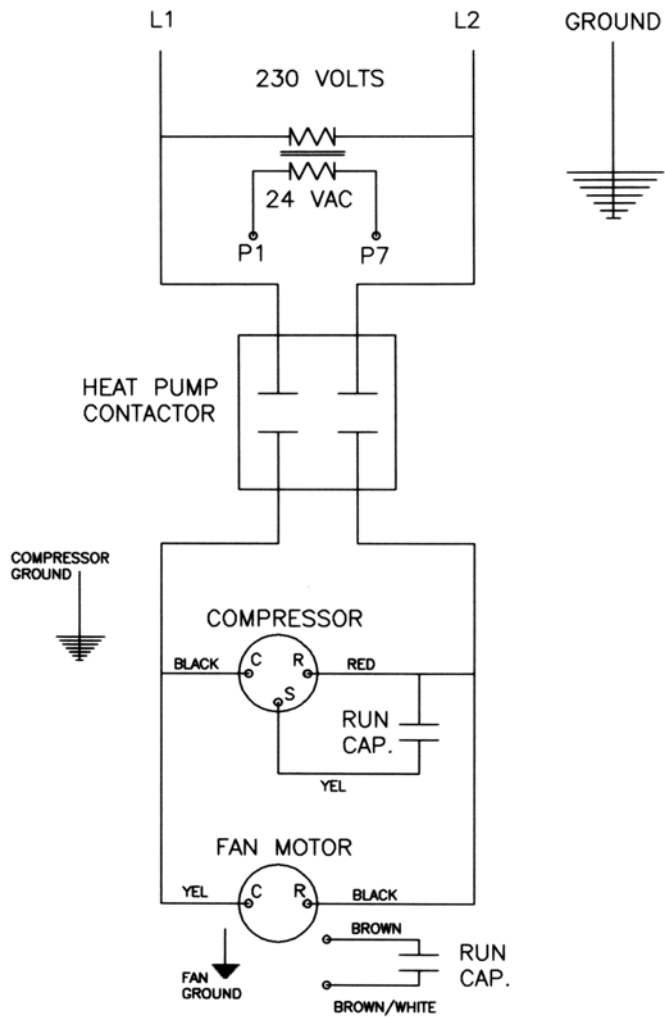

FIGURE 2
 POOL PUMP TO HOLD RELAY WIRING SCHEMATIC

FIGURE 3A
 POOL HEATER 230 VAC SCHEMATIC



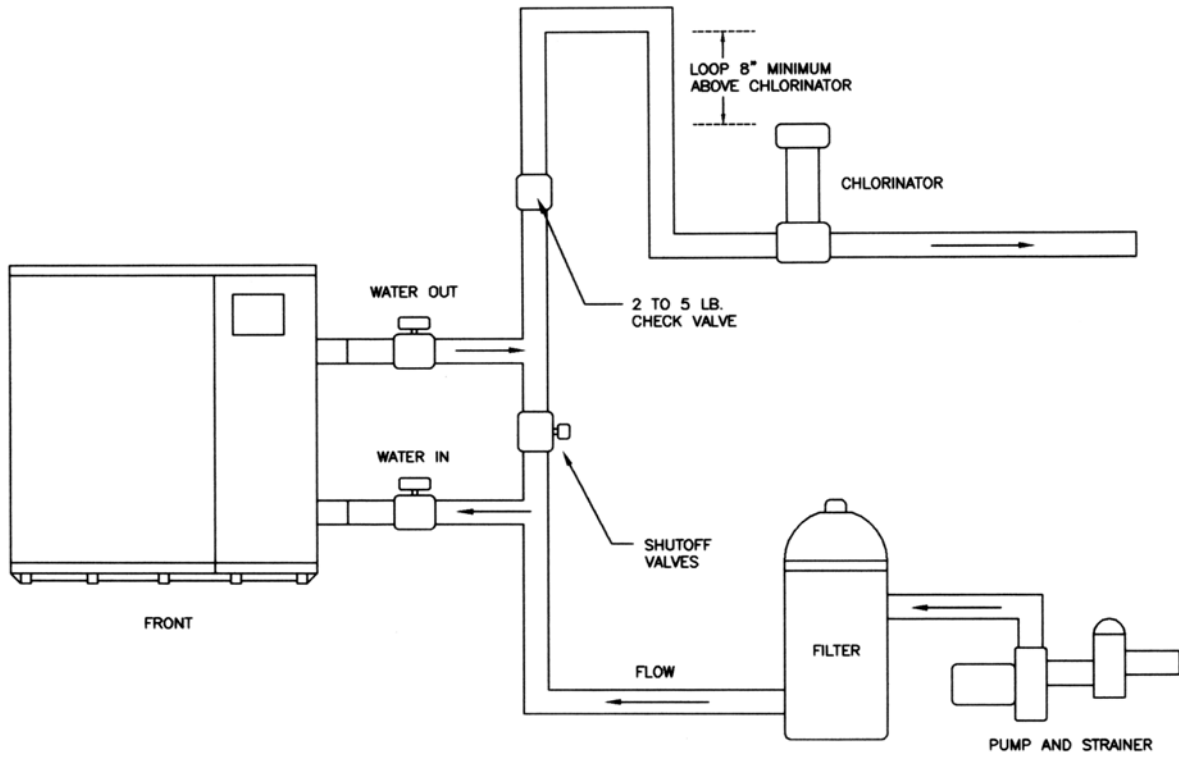

FIGURE 4 – PIPING CONNECTIONS

SHUTOFF VALVES AND BYPASS ARE FOR SERVICE ONLY
 BYPASS SHOULD BE SHUT OFF DURING OPERATION
 IF WATER FLOW IS IN THE 20 TO 80 GPM RANGE

Startup Troubleshooting

PROBLEM	POSSIBLE CAUSE	SOLUTION
Temperature display not lit Unit will not start	Check power supply to unit. Check circuit breaker or fuses Check 24 volt transformer	Turn on or reset breaker. Check transformer/replace if required.
Temperature display lit Unit will not start.	Water flow less than the 20 gpm minimum required. Time delay and anticycle timers satisfied. Temperature set too low.	Check that pump is on. Check that water is flowing through heater. Check any bypass valves that are installed. Check filtering system. Check pump and impeller. Check that pressure switch is closed. (needs 2 psi to close) Wait at least 8 min. without resetting on/ off switch or breakers. Set temperature setpoint above water temperature.
Pool water does not reach temperature setpoint.	Heater runs only when pool timer is on. Outside air temperature is low.	Turn on pool pump. Install solar blanket on pool.
Water dripping from bottom of unit.	Water vapor will condense on the outside of the evaporator coil during normal operation. Leak at pipe connection	No action. This is normal. Repair as required.

For specific controller issues, please see Chapter 9 of the Viconics HP727-S manual.

POOL HEATER TM121 / WCC 115
LIMITED WARRANTY
FOR RESIDENTIAL APPLICATIONS
(10 / 5 / 1)

Trevor-Martin Corporation warrants each Pool Heater to be free of defects in materials and workmanship for 12 months from the Date of Installation. In the absence of suitable proof of Date of Installation (Bill of sale), the Warranty Period will commence 30 days after the Date of Manufacture. Additional Warranty coverage applies to specific components as follows: Trevor-Martin Heat Exchanger has a ten (10) year pro-rated replacement warranty, compressors have a five (5) year limited warranty, Factory Service is included for the first 60 months of operation. Failures resulting from improper installation, abuse, accident, negligence, freezing, hard water, scale buildup, chemicals, external leakage, or Acts of God are specifically excluded from Warranty Coverage.

This constitutes the only Warranty in connection with this sale; and is in lieu of all other Warranties, expressed or implied, written or oral. No employee, agent, dealer or other person is authorized to give any other Warranty on behalf of Trevor-Martin Corporation; nor to assume for Trevor-Martin Corporation any other liability in connection with this product; except as may be authorized by an officer of Trevor-Martin Corporation in a signed written document.

THERE ARE NO IMPLIED WARRANTIES OF MERCHANTABILITY OR FITNESS FOR A PARTICULAR PURPOSE THAT APPLY TO THIS SALE.

LIMITATION OF REMEDY

Trevor-Martin Corporation will replace or repair, at its option, any product or component found to be defective during the Warranty Period: either by act of Factory Service on the installed unit; or if such product or component is returned to our Factory, listed below, freight prepaid, product will be repaired and returned to originator. All such returns of product require Factory authorization prior to shipment. Trevor-Martin Corporation will not accept liability for unauthorized returns.

Replacement or repair is the exclusive remedy available from Trevor-Martin Corporation for any product or component found to be defective. Trevor-Martin Corporation is not liable for unauthorized labor charges, or damages of any sort whatsoever, including incidental or consequential damages, associated with product or components returned under Warranty. For Warranty Service contact the installing Contractor or Trevor-Martin Corporation @ 1-800-875-1490.

Products or components replaced or repaired under the terms of this Warranty will be returned, transportation charges prepaid, by the best and most economical means.

Trevor-Martin Corporation
4151 112th Terrace North, Clearwater, FL 33762